

Product line

Vehicle sensors

for railroad applications

Railroad rolling stock

Packaging machines

Machine tools

General mechanical engineering

Renewable energies

E-mobility

Maritime applications



Motion sensors and integrated drive technology



*Finding solutions.
Founding trust.*

Our reliable sensors

Manufactured in Germany. Used globally.

When several hundred tons of weight are being accelerated, controlling the physical forces involved is a technical challenge. Various control systems are deployed to control both the drive and the brake as well as the train. These systems must also operate reliably under the most extreme conditions. The sensors used are directly exposed to the elements as well as rocks and dust.

That's why the electronic components of our products are protected from extreme climate conditions, humidity, shock, impact and vibration by special manufacturing methods. Our durable sensors have stood the test in rail vehicles for decades. Our plug-and-play sensor systems reliably acquire rotational speed, temperature, acceleration or mileage.

We always create individual solutions in close cooperation with our customers.

1 Traction and roll protection:
Speed acquisition and detection of torsional vibrations for drive control

2 Gear monitoring
Early wear detection

3 Automatic train protection:
Speed acquisition for safety-relevant odometry

4 Bogie monitoring:
Acquisition of rotational speed, oscillations, vibrations, shock and temperature

5 Wheel slide protection:
for brake control

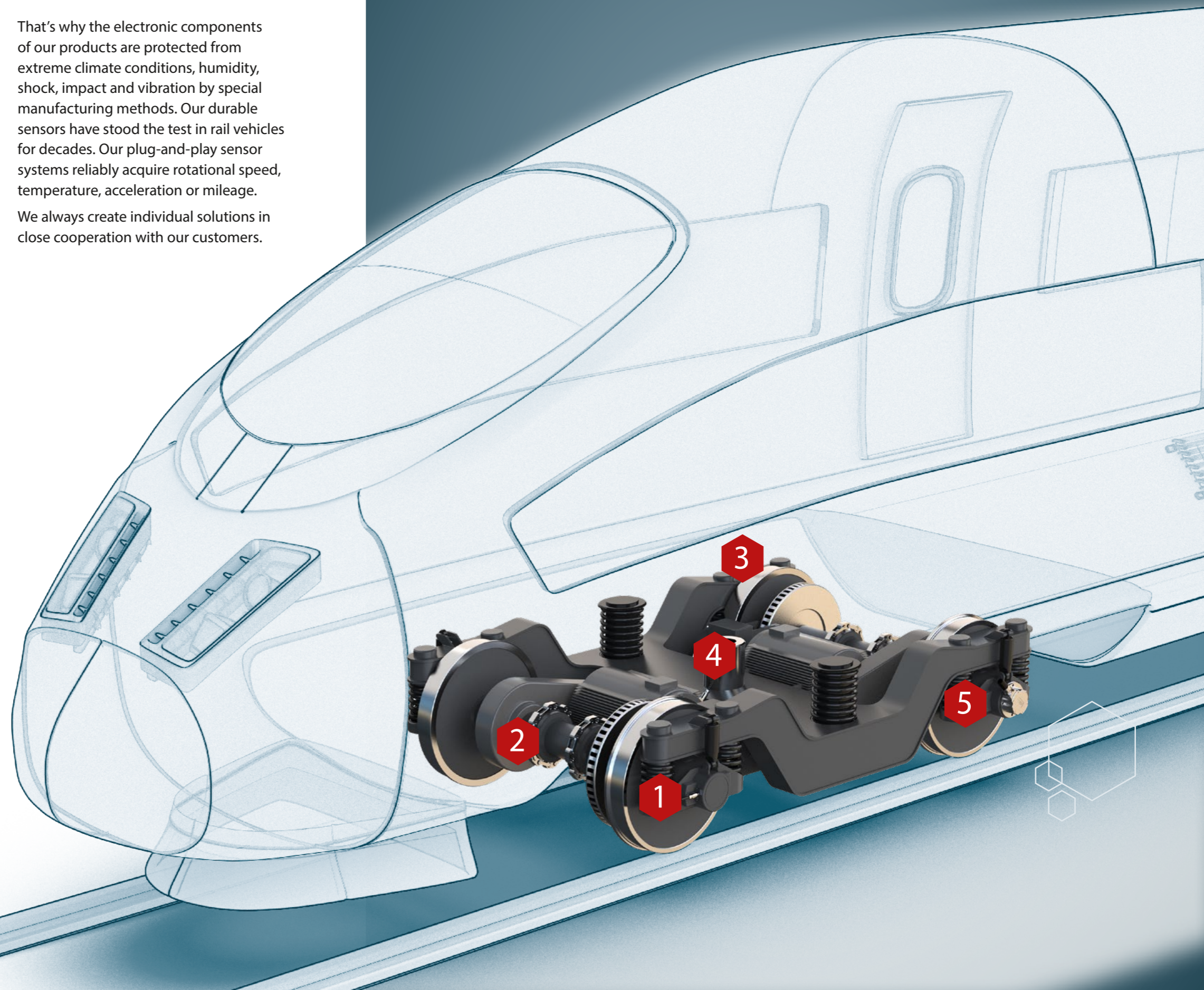

A solution for every need

First-class sensors for safe bogies

Lenord+Bauer offers the right sensor solutions for all conceivable requirements and applications in relation to the bogie.

Gear monitoring

By continuously monitoring gear components, anomalies or signs of wear can be detected at an early stage before they result in serious damage. Effective monitoring also allows you to precisely schedule maintenance intervals and actions. This minimizes unplanned downtimes and maximizes the train operating time.

Our Condition Monitoring sensors allow you to detect vibrations and oscillations. Use our CombiCODER GEL 2475CM for particularly space-saving, combined detection of speed, temperature and vibration. In addition to analog output of the vibration values, classic speed signals are also output. This also allows the expected fundamental frequencies and their harmonic frequencies to be determined in order to reliably detect any deviations in the gear.

Traction and roll protection

To provide optimal drive power, our speed sensors assist the traction systems to detect slip and torsional vibrations of individual axles quickly and accurately and to optimize torque until sufficient static friction is reestablished between the wheel and the rail. This preserves the material and ensures efficient drive and greater ride comfort.

Our high-resolution speed sensors in the pick-up housing help in situations with high torque requirements. Higher pulse numbers improve signal resolution, which has a positive effect on torque ripple, drive efficiency and ride comfort. More accurate drive control and speedier detection of torsional vibrations in the axle protect both the vehicle and the infrastructure, and enable start up under specially challenging conditions.



Wheel slide protection

Wheel slide protection systems ensure an optimum mix of braking force and braking distance in all weather conditions. If the friction values between the rail and the wheel become too low during braking, slip occurs or the wheel blocks. Thanks to our precise wheel slide protection sensors, rotational speed deviations and blocking are reliably detected and the braking force on the affected axle can be reduced in a targeted manner. This increases the service life of the wheel and rail and ensures accurate braking at the platform.

Our rotational speed and multi-system sensors not only comply with standard railroad specifications, but as an option also with special approval requirements for use with many wheel slide protection systems.

Bogie monitoring

During operation, the bogie is exposed not only to the high static weight load, but above all to the dynamic driving influences of the track infrastructure. For this reason, continuous monitoring of the loads and reactions to such loads are especially important. Wear and tear as well as material fatigue are common. Today an increasing number of parameters are used to guarantee safety. This contrasts with the limited installation space on the bogie.

Our speed and temperature sensors supply the required variables to detect any safety-related events at the bogie and to eliminate malfunctions at an early stage. If installation space is limited, combined systems are the correct choice. Our CombiCODER and multifunctional axle encoders acquire both rotational speed and temperature and acceleration, for example. In this way, they make optimal use of the space.

Our GEL 2475FD flat spot detector has integrated detection of periodic impact loads. This allows detection of flat spots on wheel tires. The classification of flat spots into different degrees of severity not only helps with early detection, but also makes workshop visits easier to plan and prevents consequential damage.

Automatic Train Protection

Automatic Train Protection (ATP) systems ensure, among other things, that the permitted speed is not exceeded and also that the distance to the preceding train is observed. One important detection parameter of these systems is travel speed. The system determines travel speed from the axle speed. Ideally, it is measured directly at the wheel set. Our extensive experience with safety-related functions makes us the right partner for challenging projects.

Our highly integrated multichannel encoders are available both as axle encoders with integrated measuring scale for assembly at the axle tip and in the familiar pick-up encoder housings for scanning existing measuring scales. Electrically isolated signal groups can supply speed information to a wide range of systems from a single encoder without requiring feedback. We also offer solutions for particularly critical security requirements such as cold movement, ETCS and CBTC.

Product qualification

100 % tested and reliable in use worldwide

A significant proportion of our products are installed in durable capital assets such as rail vehicles. Consistently excellent product quality and high reliability are thus strategic corporate goals, which we pursue holistically in all corporate areas.

Quality management for us begins in the product development stage and is a constant in all business areas. Every year, we put our measures to the test in external and internal audits. We are thus certified according to DIN EN ISO 9001, DIN EN ISO 14001 as well as the International Railway Industry Standard IRIS DIN ISO/TS 22163.

This is your guarantee for durable and reliable products. Furthermore, we offer our customers the opportunity to audit us as a supplier at any time.

Our goal is to provide you with a reliable measurement solution for your application. We are keen to meet the challenge!



EMC and environmental testing

Standard	Testing and measurement methods
DIN EN 50155	Railway applications – Rolling stock – Electronic equipment
DIN EN 50121-3-2	Railway applications – Electromagnetic compatibility – Rolling stock – Apparatus
DIN EN 60068-2-1	Environmental testing – Test A: Cold
DIN EN 60068-2-2	Environmental testing – Test B: Dry heat
DIN EN 60068-2-14	Environmental testing – Test N: Change of temperature
DIN EN 60068-2-27	Environmental testing – Test Ea and guidance: Shock
DIN EN 60068-2-30	Environmental testing – Test Db: Damp heat, cyclic
DIN EN 60068-2-64	Environmental testing – Test Fh: Vibration, broadband random and guidance
DIN EN 60529	Degrees of protection provided by enclosures (IP Code)
DIN EN 61000-4-2	Electromagnetic compatibility (EMC) – Electrostatic discharge immunity test
DIN EN 61000-4-4	Electromagnetic compatibility (EMC) – Electrical fast transient/burst immunity test
DIN EN 61000-4-5	Electromagnetic compatibility (EMC) – Surge immunity test
DIN EN 61000-4-6	Electromagnetic compatibility (EMC) – Immunity to conducted disturbances, induced by radio-frequency fields
DIN EN 61373	Railway applications – Rolling stock equipment – Shock and vibration tests

Our laboratory offers you the assurance that our products are tested in accordance with standards.

You can obtain qualified measuring systems with an internationally recognized conformity assessment upon request.

We can perform further environmental or EMC tests, for example according to DIN EN 61000-4-8, upon request.

If you wish, we can collaborate to draw up an individual test schedule. Talk to us.



Easy to mount and reliable in operation

Examples of possible cable outlets

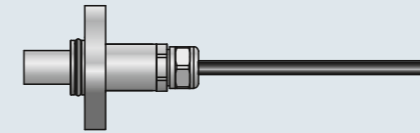

Standard, straight

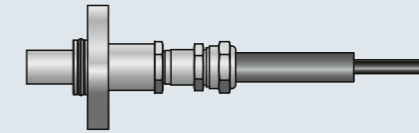

Anaconda Sealtite, straight

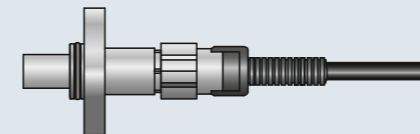

Flexible conduit, straight

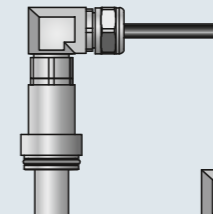

With 90° angle

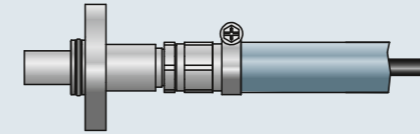

Rubber sleeve, straight

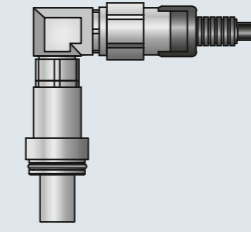

With 90° angle and flexible conduit

Plug-and-play sensors save time during assembly on the vehicle and also reduce internal expenses for procurement, storage and logistics. Allow us to handle the procurement of complex components such as connectors and cable protection and benefit from cost advantages. Save yourself the trouble of qualifying external cable assemblers. Our crimping processes are subject to the highest quality standards. Hundreds of products equipped with cables and connectors leave our factory every day. All 100 % tested and documented. Everything from a single source. Feel free to talk to us. We will be happy to advise you on the selection of connectors and cable protection systems.

Especially in railroad technology, the installed parts must comply with extensive standards and guidelines. We will be happy to advise you on how to configure your sensor with regard to the applicable fire protection standards. We use numerous standards as a basis for evaluating materials for operational safety, such as the standards DIN EN 45545-2 and DIN EN 50155. Declarations of conformity for all customer-specific variants and provision of the specific MTTF are standard for us.

Examples of possible cable ends and connectors



Flexible conduit and flying lead



Rubber sleeve and flying lead



Flexible conduit with round connector



Cable with shrinkable molded part

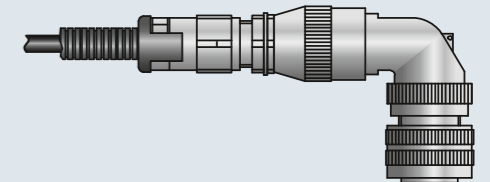

Flexible conduit with round connector angled

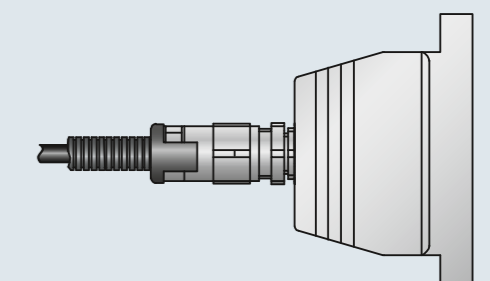

Flexible conduit with rectangular connector (HTS connector)

Speed sensors

Acquisition of rotational speed and speed according to needs

Accurate at any speed

Our speed sensors acquire movements from 0 Hz just as reliably as fast rotations up to 25 kHz. As they operate without contact, they are entirely maintenance and wear free.

Magnetic sensors with proven technology

Using the magnetic measuring method, the sensor system scans a ferromagnetic target wheel. The rotating target wheel changes the magnetic field in the sensor and thus modulates the voltage.

The electronics convert the modulated voltage into square-wave signals. The signal frequency is directly proportional to the shaft rotational speed. Our products' measurement process has stood the test in rail vehicles around the world for decades.

Lightweight construction based on the eddy current principle

Using the eddy current method, evaluation coils record the changes in conductivity of the toothed structure. Our eddy current sensors are better than standard market technology detecting movements as of 0 Hz. The target wheels used are made of electrically conductive material such as aluminum.

The ability to directly scan toothed aluminum fan propellers results in weight savings of up to 30 %. The sensor is also ideally suited for use in dirty environments, as no ferromagnetic particles accumulate on the sensor front that could impair its function. It is also a perfect solution for air-cooled electric motors where large volumes of air are circulated.

The solution for a wide range of tasks

Our speed sensors output the signals on up to eight channels. Due to electrical isolation, the sensor can issue independent signals for multiple control units. Additional diagnostic modes can also be implemented, for example to detect standstill in wheel slide protection applications and to detect cable breakages or short circuits reliably.

The direction of rotation of the axle is acquired either by a separate directional signal or by the phase offset of two channels. Here, an index pin in the flange ensures correct assignment of the channels to the direction of rotation.

Not sensitive to interference fields

In areas with high interference potentials, such as areas close to the converter power cables, their inverse signals can be connected in addition to the usual output signals. This allows common mode interferences to be reliably detected by differential evaluation.

Alternatively, sensors with current signals can be deployed in areas with high electromagnetic interference. In addition to the high electromagnetic immunity due to the principle, wire breakage and short circuits can also be reliably detected without any additional hardware.



Product advantages at a glance



Shock and vibration resistant due to encapsulation of the electronics



Electromagnetic compatibility according to DIN EN 50121-3-2



Degree of protection IP 68: Dust and water-proof according to DIN EN 60529



Simple mounting: Extremely compact design with standard flanges



Reliable at temperatures from -40 °C to +120 °C



GO! Ready for immediate use as a plug-and-play system

Whether they are part of the wider portfolio or are customer-specific – Lenord+Bauer sensors are durable, high-quality and tested to comply with standards in every respect.



GEL 247



GEL 2476



GEL 2477

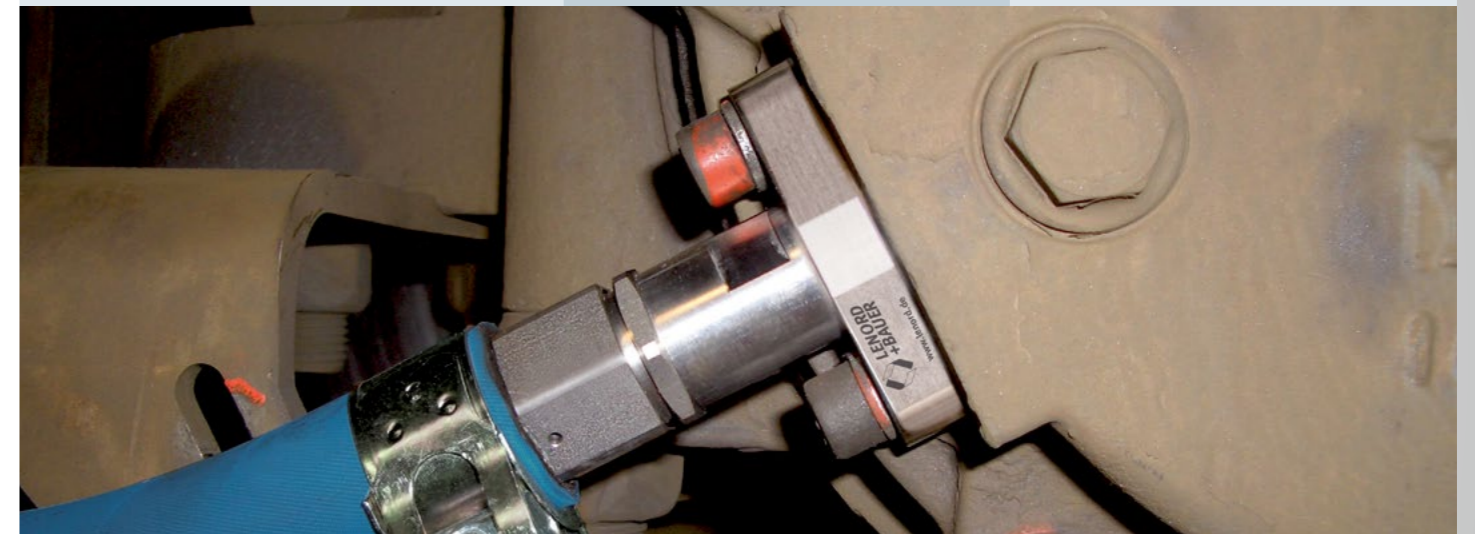

Tailor-made for your application

We adapt our sensors to your needs. If the mounting position of the sensor and target wheel requires a specific position of the active elements in the sensor tip, we position the sensor elements according to your requirements. We also design special functions and special flanges for our customers. Tell us your wishes and we will integrate, for example, a pulse divider or a self-test in the electronics.

For SIL, TSI or ATEX applications

On request, we certify products for special applications such as ATEX, SIL or for TSI applications. We coordinate all necessary components and offer you support to certify your system.

Quality from a single source

We can equip your sensors with cables, cable protection and connectors using highly specialized manufacturing processes, because complete systems save time and assembly costs. We have a permanent stock of many components for customer-specific designs.

- Various railroad cables according to DIN EN 45545-2
- Standard cable protection systems for all loads classes
- Many rail-compatible connectors from established manufacturers

Every sensor undergoes a detailed routine test before delivery. Correct execution of the core assignment and compliance with the insulation voltage and naturally all other electrical parameters are checked and documented. This is also the case for customer-specific versions. There are no exceptions.



Multisystem sensors

One sensor provides signals for up to four control systems

High-quality diagnostic units ensure greater railroad safety. The individual applications require very different signal properties. Our multi-system sensors are the space-saving solution for users with a growing number of control devices. Up to four independent speed sensors are integrated in an industry-standard housing.

Four separate sensor units are technically feasible. If necessary, every control system has its own power supply and is electrically isolated. If need be, two channels can be generated with a fixed phase relationship. The requirements of all applications can be combined in a single housing from the traction control to the brake control.

Tailored to your application

We will create an individual multi-system sensor for you. Please provide us with the following key data when submitting your inquiry:

- Number of electrically isolated systems
- Required signal patterns
- Signal output current and/or voltage
- Direction and/or standstill detection
- Flange shape required
- Special requirements (TSI, etc.)

Our specialists check the feasibility and clarify all technical details with you.

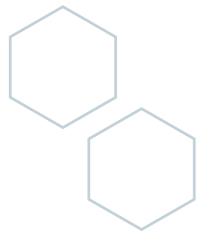

Matching precision target wheels



Product details

- Made of ferromagnetic steel
- Module from 1.0 to 3.5
- Involute gear teeth (others upon request)
- Outside diameter from 150 mm to 500 mm
- Individual inner diameter
- Ready for assembly with bores, feather keyways, etc.

When acquiring rotations, the speed sensor and target wheel form a single unit. We would be happy to manufacture the suitable target wheel for your sensor.



Sample application GEL 2475MS

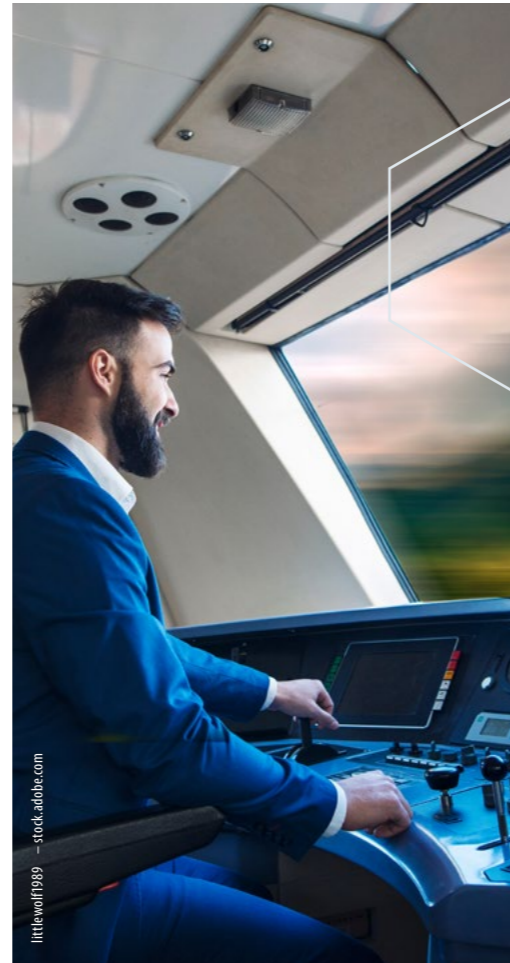

Key data

- up to 8 output signals
- 4 electrically isolated measuring systems

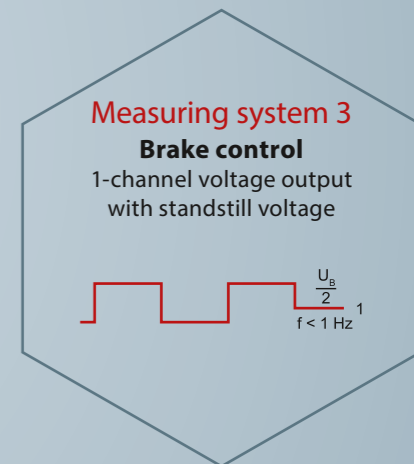
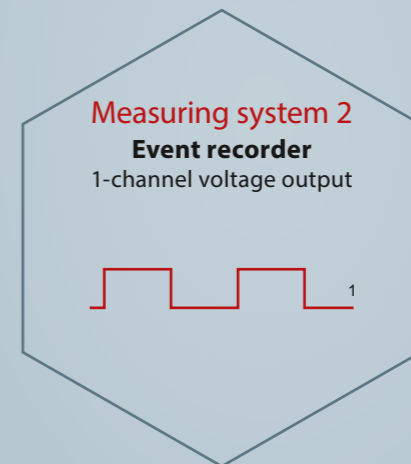
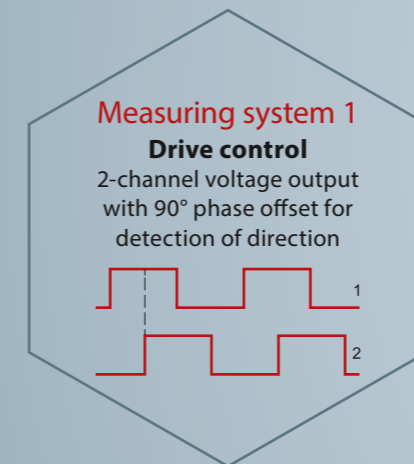

Multisystem sensor GEL 2475MS

Electrically isolated measuring systems



Threaded sensor

The multi-talent adapts to all retrofit projects

To ensure that modern train control systems receive reliable rotational speed signals, vehicle operators have to regularly replace passive sensors with active ones. Our screw-in threaded sensors are used to upgrade rail vehicles to the state of the art to enable continued operation.



GEL 2460

Space-saving assembly variant

In addition to tried-and-tested speed sensors with flange housing, threaded sensors with one or alternatively two channels are another assembly variant for threaded or through holes. These space-saving sensors can be easily integrated into existing designs without any mechanical adjustments thanks to standard thread types and nominal lengths as well as individual cable fabrication.

They acquire the rotational speed and direction of rotation directly at the motor or gearbox and detect even the smallest movements of the drive with a measuring range of 0 Hz to 20 kHz.

Robust, high-resolution sensors were developed for use in the harshest ambient conditions. They are suitable, for example, for traction control and train protection. The maintenance- and wear-free magnetic measuring system in the thick-walled stainless steel housing withstands both shocks and vibrations. Certification in accordance with DNV, SIL, ATEX or IECEx is possible as an option.

Product advantages at a glance

 Multi-channel capability

 Complies with the requirements of DIN EN 50155 and DIN EN 45545-2

 Thick-walled stainless steel housing

 Also in customer-specific thread types and lengths

 Safe detection slow motion (0 Hz)

 Special types also in small quantities

Retro vehicles are revamped flexibly and reliably using our threaded sensors.

Variety of speed sensors

Technical data	GEL 247	GEL 2471	GEL 2474	GEL 2475	GEL 2476	GEL 2477	GEL 2478	Multi system sensors	GEL 2460
Measuring method	magnet.	WS	magnet.	magnet.	magnet.	magnet.	magnet.	magnet.	magnet.
Supply voltage [V DC]	10-30	10-20	10-30	10-30	10-30	10-30	10-30	10-30	10-30
Maximum number of channels	2	2	2	2	2	2	2	4	2
Housing material	VA	VA	VA	VA	VA	VA	VA	VA	VA
Positioning with index pin	•	•		•		•	•	•	•
Target wheel module	1-3.5	2-3	1-3.5	1-3.5	1-3.5	1	1-3.5	1-3.5	1-3.5
Type test according to EN 50155	•	•	•	•	•	•	•	•	•
Degree of protection	IP 68	IP 68	IP 68	IP 68	IP 68	IP 68	IP 68	IP 68	IP 68
Target wheel material	ferrom.	ferrom.	Al/steel	ferrom.	ferrom.	ferrom.	ferrom.	ferrom.	ferrom.

Output signals									
Electrical isolation	•			•	•			•	•
Voltage output (HTL)	•	•	•	•	•	•	•	•	•
Current output			•	•	•			•	•
Standstill voltage			•	•	•			•	•
Inverted signals	•	•	•	•	•	•	•	•	•
Direction of rotation detection	•	•	•	•	•	•	•	•	•
Integrated interpolation						•			

WS = eddy current measuring technique; Al = aluminum; VA = stainless steel

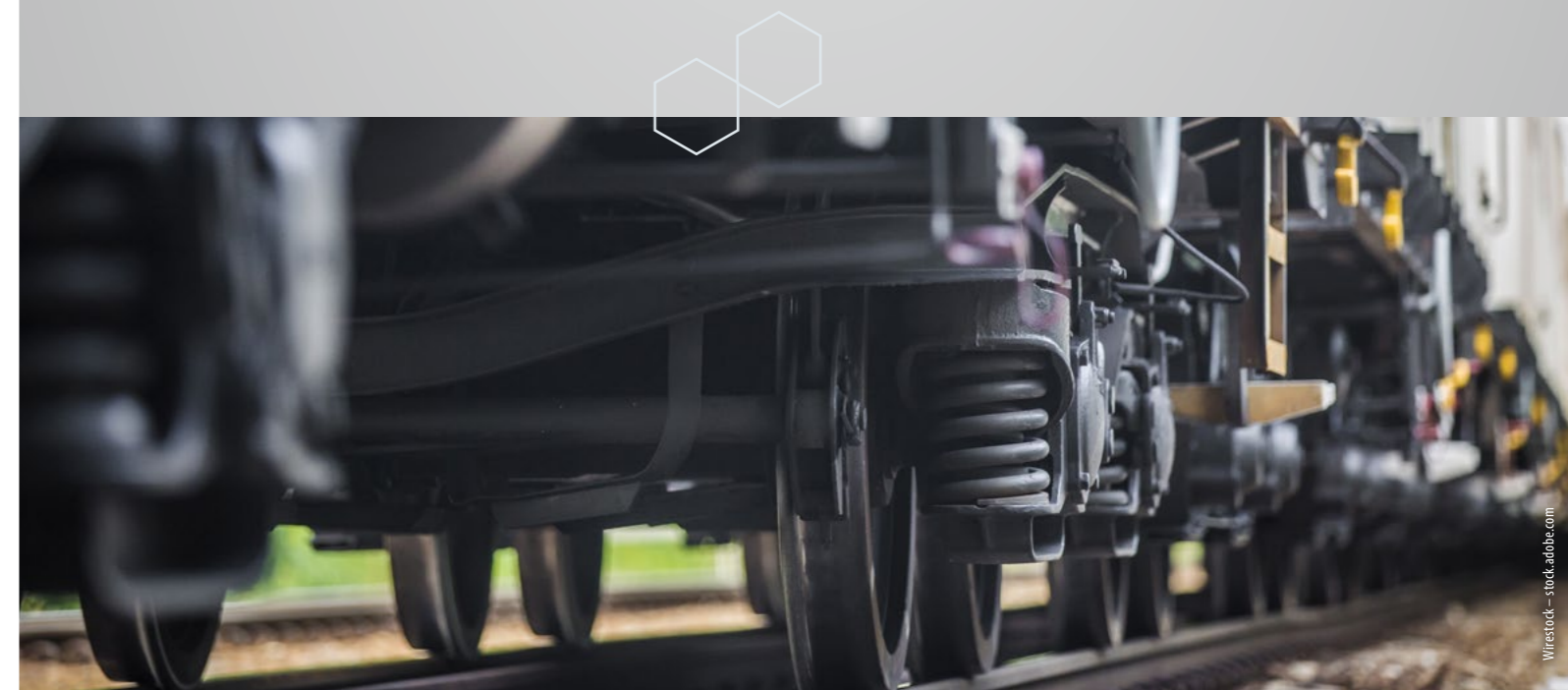

CombiCODER

Space-saving acquisition of vibrations and temperatures

The temperature of motors and bearings can indicate inefficient or even critical conditions. Our compact platinum resistance thermometers record any changes and warn of any unwanted heat build-up on the undercarriage. The compact temperature sensors according to DIN EN 60751 are available with stainless steel tubes and brass flanges. For optimal measurement, we adapt the length of the measuring tube to your application.

Mechanical influences such as flat spots in the wheel rim or imperfections in the rail place the undercarriage under stress. To detect these stresses at an early stage, we use MEMS devices, among other devices. Their measured values provide information about shocks and vibrations that have occurred.



Temperature acquisition

- Pt100 or Pt1000 measuring elements
- Measuring range from -40 °C to +200 °C
- Connection in 2-, 3- or 4-wire technology
- Tested according to DIN EN 50155
- Degree of protection IP 68

Vibration and shock acquisition

- Up to 3 measuring axes (x/y/z)
- Measuring range up to 700 m/s²
- High shock load capacity up to 4,000 g
- Analog or digital output signals



Flat spot detector for more safety

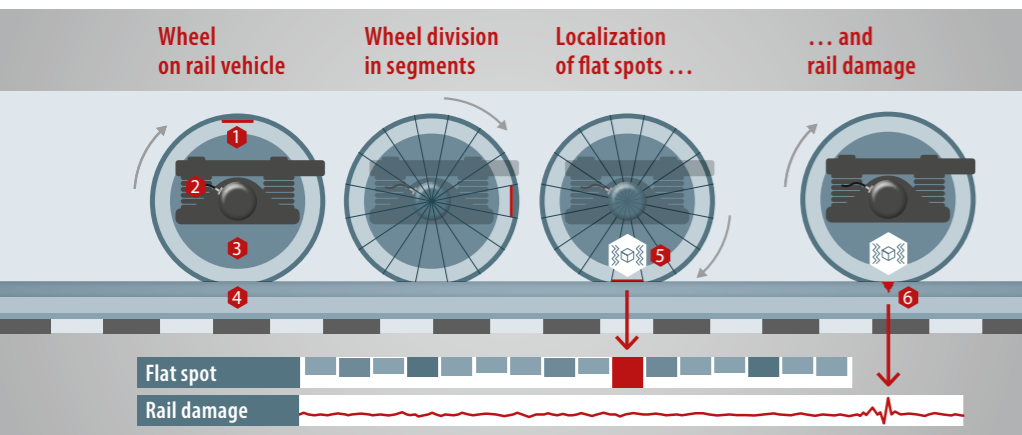

Undetected flat spots, welds or crumbling on the wheel tire can lead to serious consequential damage and have an impact on ride safety.

The GEL 2475FD can reliably detect, classify and locate damage.

- 1 Wheel tire anomaly
- 2 Flat spot detector GEL 2475FD
- 3 Rail vehicle wheel
- 4 Rail
- 5 Impact load due to flat spot
- 6 Impact load due to rail damage

Use confined space and measure three parameters



Our GEL 2475FD flat spot detector has integrated detection of periodic impact loads. This allows flat spots on the wheel tires to be reliably detected. Output is via HTL signals, so direct connection of the sensor to a bus system is not required. It also supplies classic speed signals so that existing pick-up sensors can be easily replaced. Of course, these systems are also electrically isolated from each other internally and thus without feedback. The classification of flat spots into different degrees of severity not only helps with early detection, but also makes workshop visits easier to plan and prevents consequential damage.

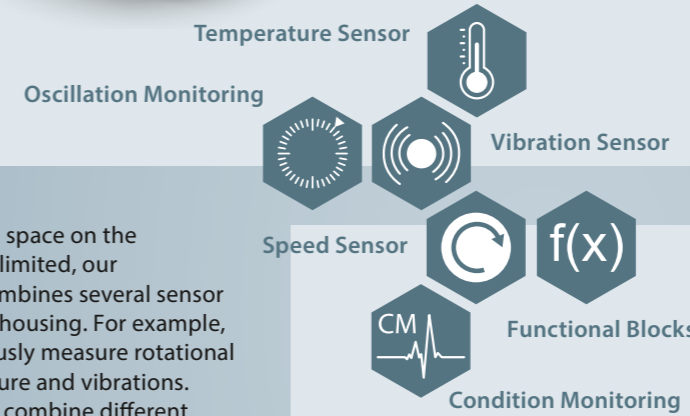

If the installation space on the undercarriage is limited, our CombiCODER combines several sensor types in a single housing. For example, they simultaneously measure rotational speed, temperature and vibrations. Alternatively, we combine different sensors individually according to your specifications and adapt the design if necessary. Your advantage: Instead of mounting three to four sensors, you only have to mount one sensor. This reduces the effort required for assembly and preventive maintenance significantly.

Upon request, we manufacture special flanges or connect, for example, the temperature sensor to a speed sensor using a cable harness.



Axle and rotary encoders

Tailored for extreme conditions

Today, precise measured values are required for real-time control. Rotary encoders with their own bearings and a wide variety of housing designs are used in this instance. A typical feature of these measuring systems is that the scanning unit and the target wheel are integrated in a single housing. Both components are precisely matched to each other. With pulse rates of up to 10,000 increments per revolution, the encoders cover all measurement requirements in the vehicle and have proven themselves in railroad rolling stock for decades.

Proven incremental rotary encoders

Our proven magnetic incremental encoders acquire the change in angle on a rotating shaft. The integrated sensors scan the built-in target wheel in contactless mode. The magnetic sensor system supplies 1-V_{pp} differential signals, HTL or TTL signals. The direction of rotation, the distance traveled and the speed of the rotating shaft can be determined from the signals generated, as an axle or motor encoder.

One axle encoder – many output signals

We offer special multi-channel axle encoders for wheel slide protection, train protection and secondary applications on the bogie. They provide different signals for several controllers and thus utilize their full potential. The sensors emit independent square-wave signals on up to eight channels. The push-pull electronics generate

up to three different pulse numbers. Output is either in voltage or current levels. The channels can be configured and output either individually or in groups with fixed phase relationship. This allows the characteristics of the output signals to be matched accurately to the control units. This solution is individually tailored to the application.

Measuring systems for high loads

Extreme shaft loads frequently occur in rail transport. We offer precision encoders with a special coupling for this special load. The integrated and flexible hollow shaft coupling with a diameter of 20 mm enables attachment to motors with marked axial and radial shaft movements. Alternatively, a rotary encoder series with a 16 mm solid shaft is available. Up to 5 independent and fully encapsulated sensor modules can be placed in a stainless steel housing. We adapt each module individually to your application and the control system. The system thus offers a wide range of applications.

Withstanding extreme weather conditions

All rotary encoders provide accurate measured values even under changing temperatures, humidity, strong vibrations and condensation. Additional protective measures can be selected for special environmental influences, such as protective coatings or condensed water outlets. Talk to us.

Our axle encoder with integrated Cold Movement Detection function (CMD) acquires movements of the wheel axle in de-energized state and provides secured information whether the vehicle was moved in de-energized state directly after the operating voltage returns. If no movement was detected, the train can return to line operation immediately with a valid position without having to pass a beacon first. Our solution is battery-free and thus low maintenance.

It is suitable for rail vehicles that are equipped with an on-board European Train Control System (ETCS) including Cold Movement Detection according to baseline 3.

Cold Movement Detection – Every movement is recorded

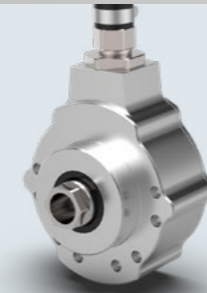

GEL 27xx



GEL 293

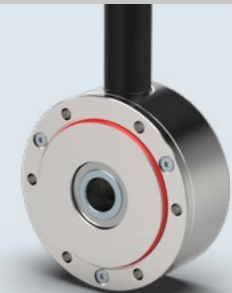

GEL 295



Technical data	Axle encoder GEL 27xx	Incremental rotary encoder GEL 293	Precision encoder GEL 295
Features	<ul style="list-style-type: none"> Multi-channel rotary encoder with up to 8 channels For mounting on internally or externally mounted bogies Output of 3 different pulse numbers 	<ul style="list-style-type: none"> Flexible hollow shaft coupling Extreme vibration protection Speedometer output 	<ul style="list-style-type: none"> Modular system with up to 5 sensors Vibration resistance up to 20 g With voltage or current output With integrated hollow shaft coupling or solid shaft
Typical number of pulses per revolution	200	10,000	1,024
Output signals	A/B/N A/B/N	A/B/N A/B/N Speedometer signal	A/B/N A/B/N Sin/Cos 1Vpp
Signal level	HTL/TTL	HTL/TTL	HTL/TTL
Degree of protection	IP 67	IP 66	IP 67
Temperature range	-40 °C to +100 °C	-20 °C to +85 °C	-40 °C to +120 °C
Supply voltage	10 to 30 V DC/5 V DC	10 to 30 V DC/5 V DC	10 to 30 V DC/5 V DC
Housing material	Aluminum	Polyamid glass fiber reinforced with stainless steel flange	Stainless steel
Max. permissible rotational speed	5,000 min ⁻¹	8,000 min ⁻¹	6,000 min ⁻¹

Sensor testing units

More safety during vehicle maintenance

Our test equipment optimizes maintenance and service work on rail vehicles. Your technicians can use the device to check the operating behavior of standard speed sensors. Provided the sensor has a current or voltage output and supplies square wave signals.

The portable device measures and compares the signals of the individual channels or tracks. Depending on the version, it outputs values such as output voltage, signal level, phase offset and duty cycle to any WLAN or Ethernet-capable display devices. The entire data conversion and evaluation take place in the testing unit, without any additional software or app.

Typical terminal devices, such as smartphones, laptops or tablets, are supported and the signals are displayed graphically using a web browser. This simplifies analysis of the operating behavior. A report generated at the push of a button documents the measured values and can be printed and saved. This makes sensor testing safer.

Connection is easy via the interface box. The interface box supplies power to the sensor and test instrument. A test jig including a target wheel with customized module is available as a complete set. A multi-function mount for standard rail sensor flanges ensures quick changeover.



Test-Kit



GEL 211R



Interface-Box

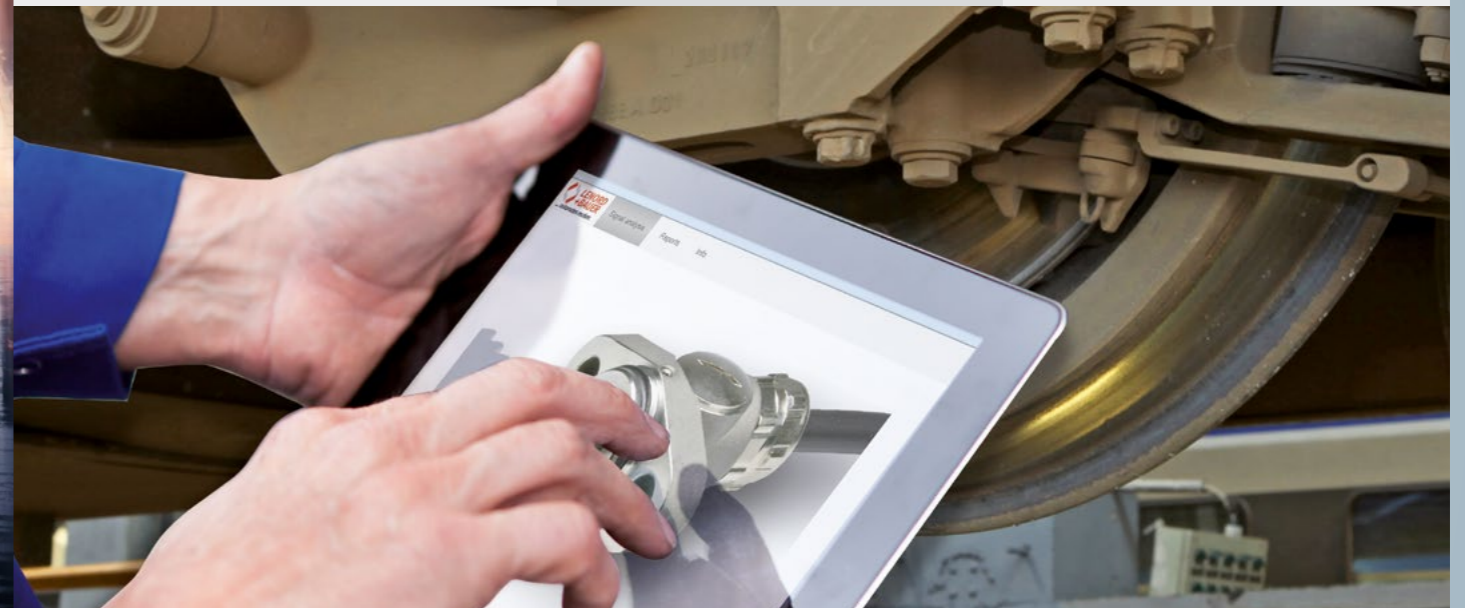

GEL 211R – for top service



Analysis with the GEL 211R test device:

- Plug and play via interface box
- Checking the sensor functions
- Easy operation via web browser on any end device such as smartphone, tablet or PC

During fault analysis in an overall system comprising sensors, screw or plug-in connectors and control systems, there is often considerable uncertainty as to which subsystem is at fault. Particularly in the case of sporadic errors, searching is frequently time-consuming and resource-intensive. In many instances, sensors are exchanged simply because there is a suspected fault. With our flexible testing unit, sensors can be tested for proper function and unnecessary vehicle downtimes can be reduced significantly.



Expertise at your side

Our know-how gives you a technological advantage

We are an international specialist in the field of motion sensors and integrated drive technology. We develop, produce and distribute leading technology solutions for the mobility and machinery sectors. Our products ensure that high-speed trains run safely, packaging machines are set up with minimum effort, tool spindles are precisely monitored and car electric drives are controlled in an energy-efficient manner. For almost 60 years, our customers have been benefiting from extensive technical consultancy competence and our knowledge of applications.

We are the competent partner for you when it comes to efficiently integrating sensors and actuators, intelligently transforming signals into value-added functions and making them accessible interactively. With us, data streams become usable information at the point of origin. Integration into your system environment thus becomes possible intuitively.

Rely on our experience, which guarantees you low lifecycle costs, high availability and digital future reliability.

Lenord+Bauer – Finding solutions. Founding trust.



High quality standards

To ensure excellent product quality and high failsafe performance, we naturally have a consistent process landscape and are certified as per DIN EN ISO 9001, DIN EN ISO 14001 and DIN ISO/TS 22163 (IRIS). This process landscape is monitored and confirmed annually by an external body. In addition, you can of course audit us as a supplier.

Active in future markets worldwide

1965
Lenord, Bauer & Co. GmbH is set up in a basement in Oberhausen



1993
Sensors for high precision and speed in machine tool applications



1999
Pole wheel position and speed encoders prove themselves under extreme operating conditions in ship propulsion systems

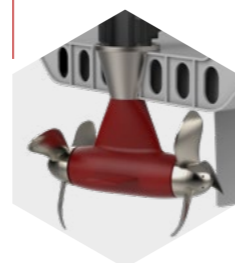

1996
Robust and wear-free sensor solutions for rail traffic

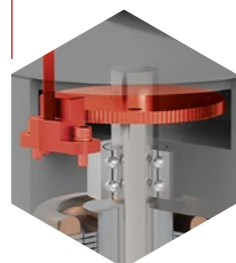

1973
The company headquarters is built in Oberhausen



2008
Drive technology for packaging machines: The first generation of positioning drives is launched on the market



2011
Internationalization: New subsidiary is established in Shanghai



2012
New production plant in Gladbeck is inaugurated

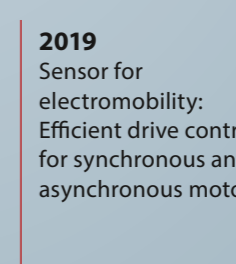

2019
Sensor for electromobility: Efficient drive control for synchronous and asynchronous motors



2021
Lenord+Bauer Italy and USA are launched

The optimum solution for you

The right partner for every issue

Whether you have a new or subsequent development, we provide support in the form of our know-how for every phase of your project. Our vision is to inspire our customers as a solution provider for sensor- or actuator-based system intelligence. We offer you comprehensive support right from the initial contact to our after-sales service.

What if your application needs an individual sensor or you need information about a specific product? Our support team will clarify all technical issues in detail and provide you with a cost estimate without delay. Just submit us your inquiry.

Technical consultation

+49 208 9963 215 // support@lenord.de

Order processing

+49 208 9963 216 // kundencenter@lenord.de



We are available to offer you advice and support at every stage of your project.



Information available without delay

Whether you are looking for product brochures, technical information, manufacturer's declarations or certificates, you are sure to find them in our download area. If you are planning a new installation or modernization, we will also be happy to provide you with our STEP files on request.

www.lenord.de/en/service/download-area



Available globally

For you locally

Lenord, Bauer & Co. GmbH

Dohlenstrasse 32
46145 Oberhausen
Germany
Phone +49 (0)208 9963 0
www.lenord.de

Lenord+Bauer Italia S.r.l.

Via Gustavo Fara, 26
20124 Milano
Italy
Phone +39 340 1047184
www.lenord.com

Lenord+Bauer USA Inc.
32000 Northwestern Highway
Suite 150
Farmington Hills, MI 48334
USA
Phone +1 248 446 7003
www.lenord.com

**Lenord+Bauer
Automation Technology (Shanghai) Co., Ltd.**
Block 42, Room 302, No.1000, Jinhai Road
201206 Shanghai
China
Phone +86 21 50398270
www.lenord.cn

Motion sensors and integrated drive technology



*Finding solutions.
Founding trust.*